

Type CFD

Fast-Acting Micro Fuses Series



Description

CFD, Fast-Acting Type, 250V rated, designed in accordance to IEC60127.3, GB/T9364.3, UL 248-14.

Features

- Lead-free
- Reduced PCB space requirements
- Direct solderable or plug-in versions
- Low internal resistance
- Vibration resistant
- Internationally approved
- Shock safe casing
- Halogen free

Applications

- Power supplies
- Consumer Electronics
- Adapter
- Battery Chargers
- Industrial Controllers

Agency Approvals.

Safety Agency	Agency File Number	Ampere Range Volt@I.R.ABILITY
	R 50540808	250mA~3.15A 35A@250V AC 4A~6.3A 10In@250V AC
	2020970207000098	250mA~3.15A 35A@250V AC 4A~6.3A 10In@250V AC
	E485357	250mA~15A 50A@250V AC 250mA~15A 50A@125V AC

Electrical Characteristics for Series

% of Ampere Rating	Opening Time
150%	1 Hour, Min
210%	30min, Max
275%	10ms Min, 3s Max
400%	3ms Min, 300ms Max
1000%	20ms Max

Electrical Characteristic Specifications by Item

Catalog Number	Rated Current	Voltage Rating	Breaking Capacity	Melting Integral 10In min(A2S)	Agency Approvals		
					TUV	CCC	cULus
CFD0250	250mA	125VAC 250VAC	50A@125V AC 50A@250V AC	0.08125	●	●	●
CFD0315	315mA			0.10915	●	●	●
CFD0400	400mA			0.14400	●	●	●
CFD0500	500mA			0.22500	●	●	●
CFD0630	630mA			0.35721	●	●	●
CFD0800	800mA			0.44800	●	●	●
CFD1100	1A			0.70000	●	●	●
CFD1125	1.25A			1.25000	●	●	●
CFD1160	1.6A			2.30400	●	●	●
CFD1200	2A			4.00000	●	●	●
CFD1250	2.5A			5.62500	●	●	●
CFD1315	3.15A			7.93800	●	●	●
CFD1400	4A			12.8000	●	●	●
CFD1500	5A			20.0000	●	●	●
CFD1630	6.3A			35.7210	●	●	●
CFD1700	7A			40.810			●
CFD1800	8A			45.615			●
CFD2100	10A			50.123			●



Temperature Re-rating Curve

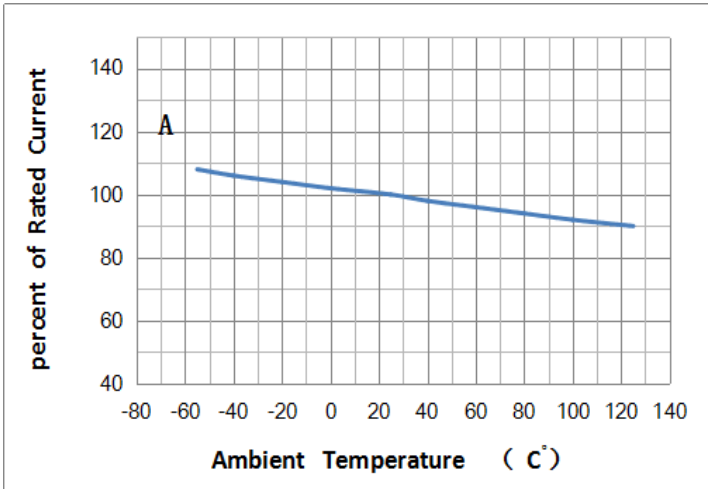

Average Time Current Curves

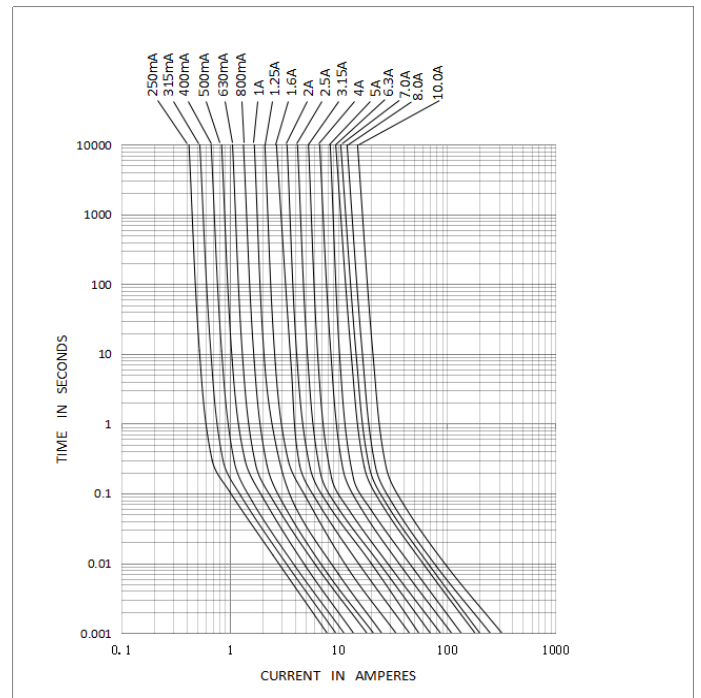

Soldering Parameters-Wave Soldering

Lead-Free Wave Soldering Profile	
Wave Soldering Parameter	
Average ramp-up rate	200°C/second
Heating rate during preheat	Typical 1-2°C/second Max 4°C/second
Final preheat temperature	Within 125°C of Soldering temperature
Peak temperature	260°C
Time within +0/-5°C of actual peak temperature	10 seconds
Ramp-down Rate	5°C/second max

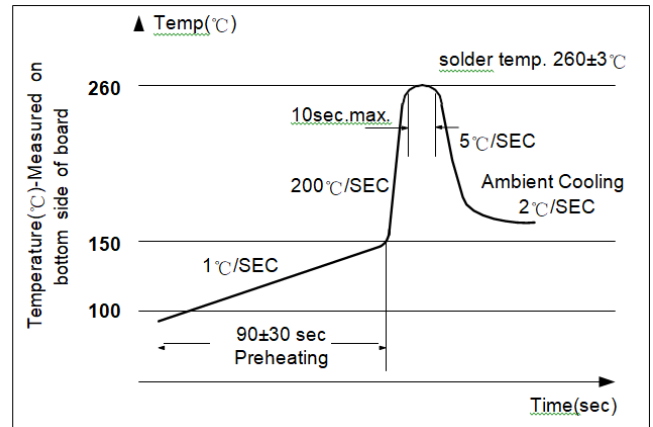

Type CFD

Fast-Acting Micro Fuses Series



Product Characteristics

Materials	Glass Body Nickel Plated Brass Caps Lead Wire :Diameter 0.8mm、0.60mm
Lead Pull Strength	10 N(IEC 60068-2-21)
Soldering Parameters	260℃, ≤10 sec.(wave) 350℃, ≤3 sec.(soldering iron)
Soldering Heat Resistance	260℃, 10 sec.(IEC 60068-2-20) 350℃, ≤3 sec.(soldering iron)

Operating Temperature	-55℃ to +125℃(consider de-rating)
Climatic Category	-40℃ to +85℃/21 days (EN 60068-1, -2-1, -2-2, -2-78)
Stock Condition	+10℃ to +60℃ Relative humidity ≤75% yearly Average, without dew, maximum Value for 30 days-95%
Vibration Resistance	24 cycles at 15 min. each (EN 60068-2-6) 10-60 Hz at 0.75 mm amplitude 60-2000 Hz at 10 g acceleration

Mechanical Dimensions(Unit:mm)

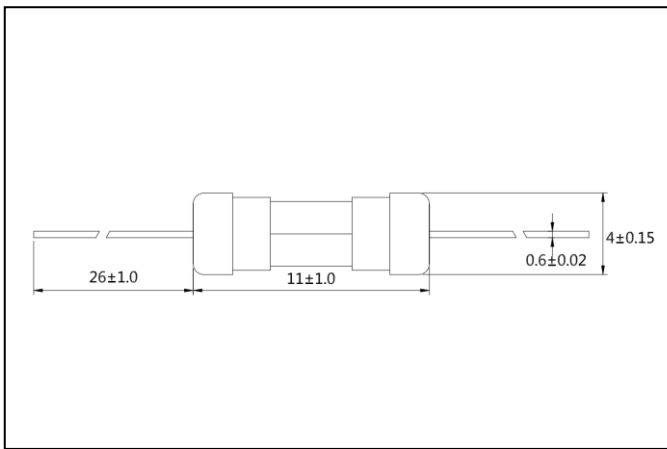

Ordering Information

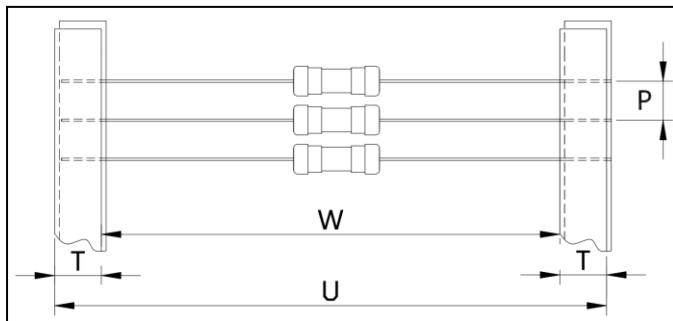
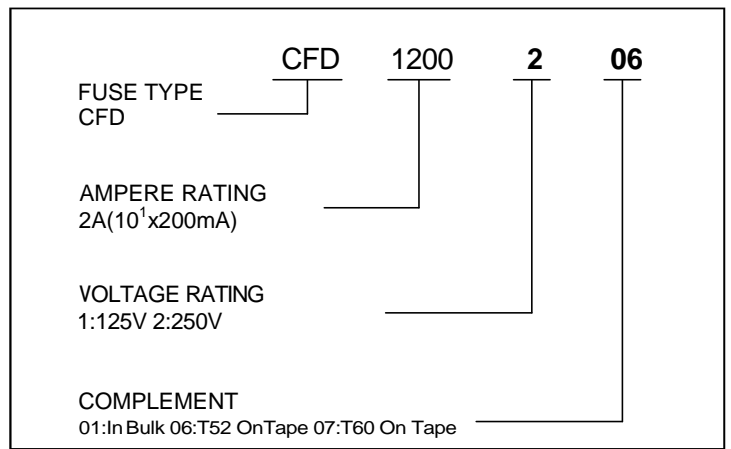

编带标准	W	U	T	P
T52	52±1.5	65±1.5	6±0.2	5±0.05
T60	60±1.5	73.5±1.5	6±0.2	5±0.05

Packaging

Packaging Option	Packaging Specification	Quantity
On Tape	N / A	1000pcs & 1500pcs
In Bulk	N / A	300pcs